

Spyder3 Color CL

Bilinear Color Linescan



Overview

Low-cost, ease of use, flexibility.

Teledyne DALSA's Spyder3 Color CL camera is a color line scan camera based on the successful Spyder3 dual line scan monochrome model. This camera provides a low cost solution with high color fidelity, flexibility, and ease of use.

The Spyder3 Color CL has the red and blue color pixels alternating in one line and all the green pixels in the other line with no spacing between the two lines to minimize image artifact. The camera offers several color output format options, including RGB, RG/BG, or G only to meet different imaging requirements.

The Spyder3 Color CL camera also incorporates advanced features such as flat field correction, automatic white balance, and is pre-calibrated to light sources such as white LEDs, for ease of use.

Key Features

- 2k and 4k resolutions
- RGB, RG/BG, or G output formats
- Pre-calibrated light sources
- Cost-effective
- Ease of use
- Camera Link configuration

Programmability

- Automatic white balance
- Color correction
- Bidirectional
- Flat field correction

Typical Applications

- Wood and tile inspection
- Cotton and textile
- Food, drug, and tobacco inspection
- Recycling sorting
- General machine vision

Specifications

Resolution	2048 x 2 pixels / 4096 x 2 pixels
Data Rate	80 megapixels per second
Max. Line/Frame Rate	18 kHz / 9 kHz
Pixel Size	14 μm x 14 μm / 10 μm x 10 μm
Data Format	8 bit, 12 bit selectable
Output	Camera Link
Lens Mount	M42 x 1, C, F
Responsivity	700 DN(nJ/cm ²)@0dB, 12 bit 400 DN(nJ/cm ²)@0dB, 12 bit
Dynamic Range	60 dB
Nominal Gain Range	± 10 dB
Size	72 mm x 60 mm x 50 mm (2k) 85 mm x 65 mm x 50 mm (4k)
Mass	300 g
Operating Temp	0 °C to 50 °C
Power Supply	+12 V to +15 V
Power Dissipation	< 9 W
Regulatory Compliance	CE and RoHS
Control	MDR26 female Camera Link
Data	Shared with control
Power	Hirose 6 HR10 pin male
Example Part Number	SC-30-04k80-00-R

Spyder3 Color CL

Bilinear Color Linescan

The Spyder3 Color CL camera is a cost-effective and easy-to-use bilinear color linescan camera.

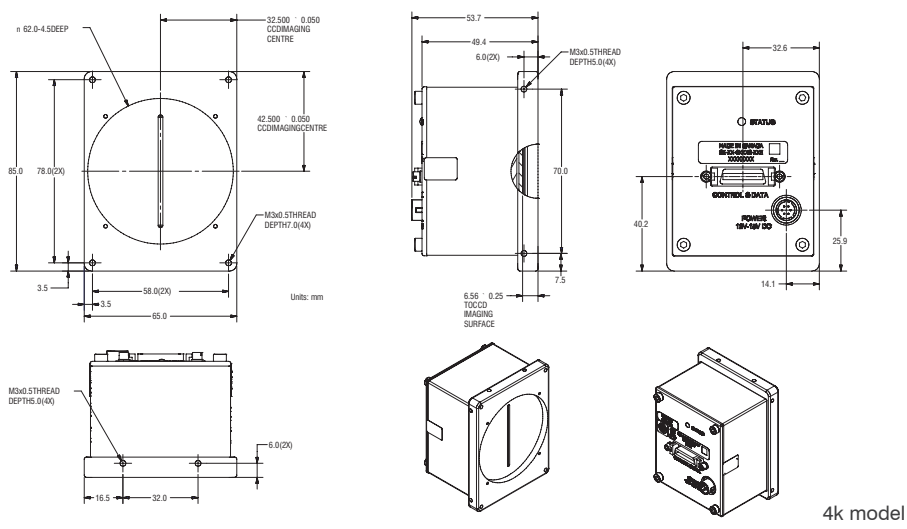
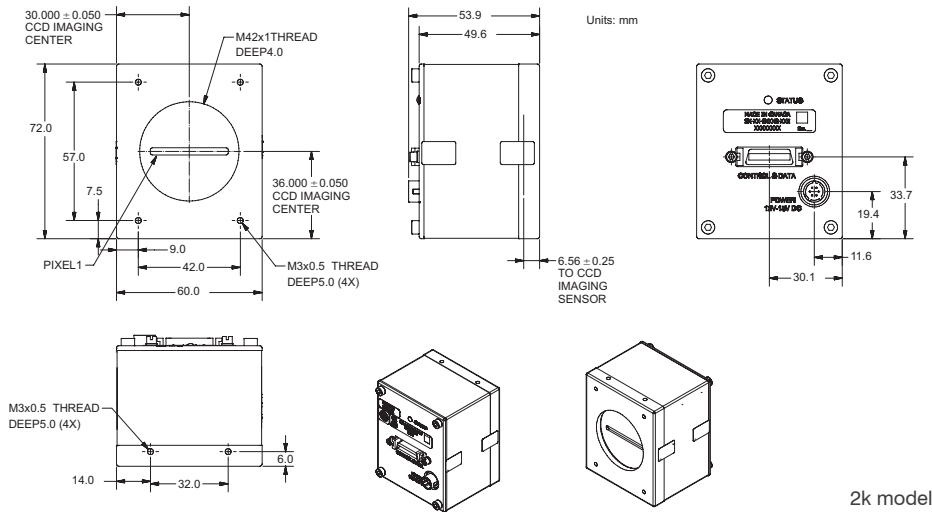
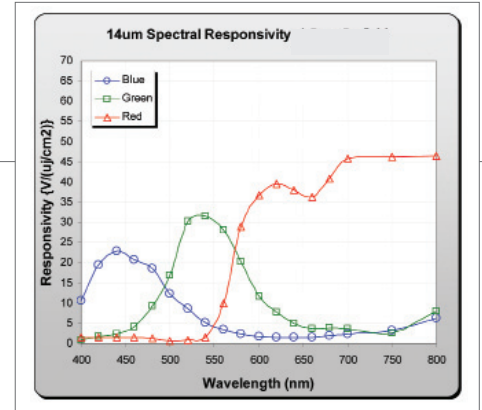

www.teledynedalsa.com

Americas

Boston, USA
 Tel: +1 978-670-2000
sales.americas@teledynedalsa.com

Europe

Munich, Germany
 Tel: +49 8142-46770
sales.europe@teledynedalsa.com

Asia Pacific

Tokyo, Japan
 +81 3-5960-6353
sales.asia@teledynedalsa.com

Teledyne DALSA is an international leader in digital imaging and semiconductors and has its corporate offices in Waterloo, Ontario, Canada.

All trademarks are registered by their respective companies. Teledyne DALSA reserves the right to make changes at any time without notice. © Teledyne DALSA 2011. 03-070-20022-01

