

PART NUMBER: 010-300700

PRODUCT DESCRIPTION: The SCDI-50-FO provides continuous diffuse illumination in the same optical path as the camera. It is designed for applications that have uneven specular surfaces requiring uniform lighting. Requires fiber optic light source.

ILLUMINATION:

Lighting Technique: Continuous Diffuse
Source Type: Fiber Optic
Spectrum: Dependent upon source
Light Delivery: Diffused
Light Aperture: 50 mm x 38 mm
 (2 in. x 1.5 in.)
Suggested Field Of View: 25 mm (1 in.)
Suggested Stand-Off: 12 mm (0.5 in.)

MECHANICAL:

L x W x H: 142.9 mm x 57.2 mm x 52.4 mm
 (5.63 in. x 2.25 in. x 2.06 in.)
Mounting: (2) ¼-20
Housing Material: Black Anodized Aluminum
Weight: 210 grams (7.4 oz.)
Accepts Ferrule Ø: 10 mm (0.393 in.) 2 Leg Bundle

ENVIRONMENTAL:

Max. Operating Humidity: 95% non-condensing
Operating Temp.: 40°C (104°F)
Storage Temp.: 50°C (122°F)

ACCESSORIES:

Part Number	Description
238-000602	LG-2, Dual guide
238-001000	CS-1, AC Light source
238-001100	CS-2, DC Regulated light source

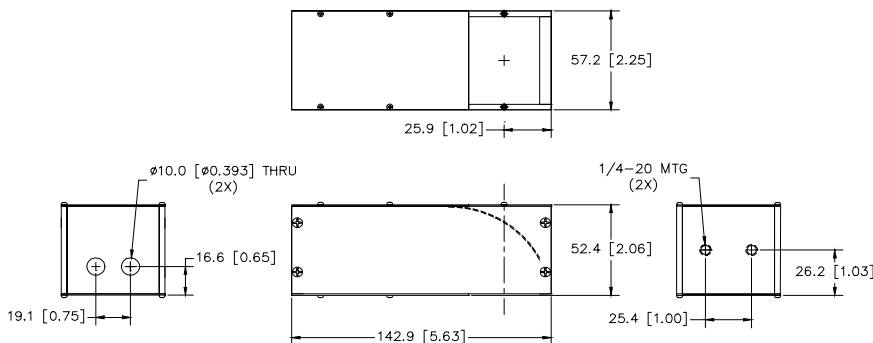

All RVSI/NER Products come with an Industry-Leading 2-Year Warranty

Products are protected under US Patent #s; 5,461,417; 5,187,611; 5,539,485; 5,301,402; 5,604,550; 5,684,530; 5,713,661

NER Document: CU-010-300700 - Revised: 02/21/01